

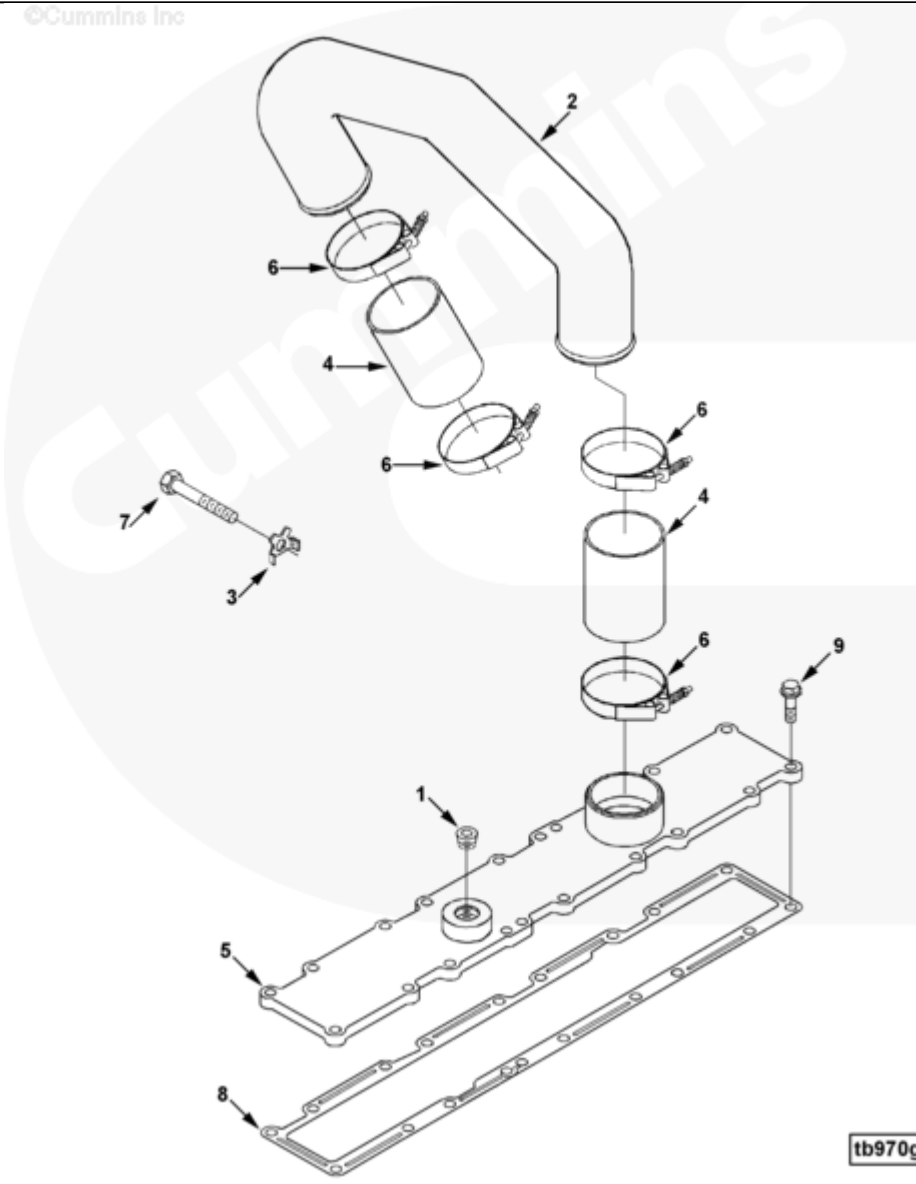

# Parts Catalog - Option Detail

Electronic Parts Catalog - Option Detail				
Option	Group	Graphic	Film Card	Date
TB90075-03	10.06.1	tb970gl	Z	10-MAR-04
<b>Engines</b>	6C8.3, C GAS PLUS CM556, G8.3, G8.3 CM558, GTA8.3 CM558, ISC CM2150, ISC CM554, ISC CM850, ISC8.3 CM2250, ISC8.3 G CM2180 C101, ISL CM2150, ISL CM554, ISL CM850, ISL G CM2180, ISL8.9 CM2150 L110, ISL8.9 CM2880 L112, ISL9 CM2150 SN, ISL9 CM2250, ISL9 CM2350 L101, ISL9 CM2350 L111, ISLE4 CM850, L GAS PLUS CM556, L8.9, L8.9 L121, L8.9G CMOH2.0 L125B, L9 CM2350 L116B, L9 CM2350 L119B, L9 CM2350 L120C, L9 CM2350 L123B, L9.3 L105, L9.5 L117, L9N CM2380 L124B, QSC8.3 CM2250, QSC8.3 CM2880 C102, QSC8.3 CM554, QSC8.3 CM850(CM2850), QSL9 CM2250, QSL9 CM2250 L115, QSL9 CM2350 L102, QSL9 CM2350 L107, QSL9 CM2350 L118, QSL9 CM2350 L122, QSL9 CM554, QSL9 CM850(CM2850), QSL9 G CM558, QSL9 M CM2250 L106, QSL9.3 CM2880 L113			



tb970gl

[SMALL](#) | [MEDIUM](#) | [LARGE](#)

Cart	Ref No	Part Number	Part Description	Required	Remarks
View My Cart					
		TB90075-03	Turbocharger Location		MR - LOCATION, TURBOCHARGER... (More)
					Engine Family: C Series
					Cylinders: 6
					Exhaust Outlet Location:
					HMFO
					Turbo Exhaust Location:
					- Front Face of Block (mm):
					377.4
					Exhaust Vertical from Crank
					Centerline (mm): 602.9
					Exhaust Horizontal from Crank
					Centerline (mm): 254.7
					Aspiration: Turbocharged
					Crossover Routing: Top
					Standard
					Oil Supply Routing: Outboard
					Intake Cover Provided: Yes
					Turbine Outlet Flange Type:
					Half Marmon
					Manifold Type: Dry
					Turbo Type: Non-Wastegate
					Requires Air Heater/Spacer:
					No
					Intake Cover Opening
					Position: Rear
					Compressor Outlet Flange
					Type: Half Marmon

					Compressor Outlet Diameter
					(mm): 50.8 (2in)
					Compressor Outlet Fixed
					Location (CCW)(deg): 20
					Additional Mounting Bosses:
					6
					Turbo Drain Location: Front
					Drain
					Bearing Housing Manufacturer:
					Holset
					CPR Angle: 200
					Turbine Angle: 0
					Turbo Drain Tube Type:
					Flexible
					Exhaust Support Flange: 2 -
					M14 92.50mm Apart
					Turbo Model: HX40
					Alternator Support Provision:
					No
					Manifold Style: 1 Piece
					Base Turbo ID17 Number:
					3595507
					Bearing Housing Cooling
					Provision: Oil Cooled
<input type="checkbox"/>	1	3008468	Pipe Plug	1	1/2 NPT.
<input type="checkbox"/>	2	3906742	Air Tube	1	
<input type="checkbox"/>	3	3914708	Lock Plate	12	
<input type="checkbox"/>	4	3970407	Plain Hose	2	
<input type="checkbox"/>	5	3922648	Intake Manifold Cover	1	

<input type="checkbox"/>	6	<a href="#">3924386</a>	T-Bolt Clamp	4	
<input type="checkbox"/>	7	<a href="#">3929537</a>	Hexagon Head Cap Screw	12	M10 x 1.50 x 70
<input type="checkbox"/>	8	<a href="#">3936993</a>	Intake Manifold Cover Gasket	1	
<input type="checkbox"/>	9	<a href="#">3938036</a>	Hexagon Flange Head Cap Screw	18	M8 x 1.25 x 30

© 2019 Cummins Inc., Box 3005, Columbus, IN 47202-3005 U.S.A.  
Terms of Use and Disclaimers | Recommended System Requirements  
Need Assistance? Please click on the Contact Us button in the top right corner of any page.